

Digital Communications in ELECTRICAL GENERATING SYSTEMS

AUTHOR

NICOLE DIERKSHEIDE

Senior Product Manager

KOHLER Power Systems

INTRODUCTION

Today, electrical generation systems are rarely used as isolated, stand-alone systems. More often, they need to communicate with peripheral devices, other generation systems, building-management systems or remote monitors. As a result, there are a number of technologies used to enable communication between electrical generation systems and other equipment. If you're involved in specifying, installing or maintaining electrical generation systems, you'll find it helpful to understand how these communication technologies work to meet your needs and the requirements of the building. It's important to involve all stakeholders when you discuss integrating the existing systems with the electrical generation system. Mutual agreement on the needs and desired functionality will ensure a system that operates as required. Specifying the correct communication technologies at the beginning can save you and your clients hours of frustration as you try to make mismatched systems work or have installation delayed while you order the correct parts.

The stakeholder team should ask these questions:

- Who needs to be part of this discussion? Participants could include information technology, building maintenance, production management and energy management personnel.
- What existing systems need to communicate with the electrical generation system?
- What information/status indication do you need to gather from the electrical generation system? What exact data do you need communicated?
- Where does this data need to be sent? How long is the distance from electrical generation system to end device?

- What is the communication hardware and protocol employed by the building-management system devices (or other systems) that will connect to the electrical generation system? What hardware and protocol should be specified to operate with the existing systems?

This paper provides information on digital communication systems used in electrical generation systems that will help you understand why the answers to these questions are so important. When the stakeholder team incorporates this knowledge and answers the questions, they'll be able to develop a comprehensive, well-thought-out electrical generation system specification and avoid pitfalls during installation and use.

WHAT COMPRISES A COMMUNICATION SYSTEM WITHIN AN ELECTRICAL GENERATION SYSTEM?

A communication system consists of two separate, independent components: the hardware and the protocol. You can think of the hardware as the physical devices—things you can touch—and the protocol as the software that allows data to flow between the hardware.

In a human model, the hardware elements are the people and the protocol is the language. See *Figure 1*. Usually, the communication challenge for humans is the potential for differences in language. Each person must follow certain grammatical rules for the communication to be meaningful. Speed can also be a factor. Most of us have experienced listening to someone who is hard to follow because they talk too fast, or someone else who tries our patience because they talk so dreadfully slow. Communication networks can experience similar issues that are like a conversation being interrupted by others, or the person you're talking with going off on a tangent and losing the main point of the conversation. Additionally, if there is great enough distance between humans, then additional hardware is a required, and if the hardware cannot connect, such as through a telephone, the language cannot be transmitted. These are the standards in human communication.

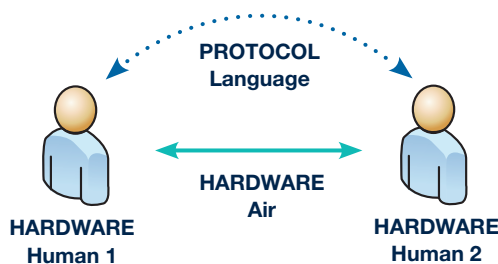

Figure 1: Human Communication Model

Communication between electronic devices is like communication between people – with similar complexities and issues. In a communication system, the hardware is composed of digital circuitry, which meets precise timing and power requirements put forth by an international standards committee. Because of this standardization, the hardware component of the communication system tends to be straightforward. An everyday example of communication hardware would be a USB (Universal Serial Bus) cable and connectors between a PC and a printer.

The protocol, or language, used to communicate over hardware is open to a much greater degree of variation. There can be multiple protocols (or languages) that communicate through a given type of hardware. Additionally, some protocols are created as industry standards. Similar to the hardware standards referenced, protocol standards define the manner in which the language is composed, so two devices connected through the hardware can talk to each other if using the same protocol. If a protocol is not defined by an industry standard, then it is considered proprietary. Information about proprietary protocols is not usually widely shared. Only other developers who know its details can develop products that will be able to communicate through the proprietary protocol.

The use of a USB memory stick is an example of a standard protocol. Think of plugging in a memory stick from one computer to another. Each computer can recognize it because it adheres to a standard. An example of a proprietary protocol is the in-vehicle communication system used by mechanics' diagnostic computers to service your automobile. The communication between the engine computer and the other car components is via proprietary protocols unique to each auto manufacturer.

While preparing an electrical generation system specification, it is vital to gather communication hardware and protocol information for each device or system that must communicate with the new electrical generation system.

The collection of this hardware and protocol data will ensure appropriate system functionality. It is also important to identify any adapters that may be necessary to convert from one hardware and/or protocol to another. The following sections describe common communication hardware/networks and protocols used in electrical generation systems.



Figure 2: Euroblock Connector

RS-485

RS-485 SERIAL NETWORKS (HARDWARE)

The RS-485 standard defines a physical connection for serial networks. It should not be confused with RS-232, another serial network standard that was typically deployed on computers in the past. Developed in the early 1970s, RS-485 is still extremely popular in industrial communication products today. The RS-485 standard defines the physical manner in which the devices are connected as twisted-pair with a specific configuration of what is transmitted on each connection point. When selecting the cabling, it must be defined as RS-485 twisted-pair. KOHLER Power Systems recommends Belden as a high-quality cable selection. RS-485 does not define the physical characteristics of the connection points on each end. A Euroblock connector is typically used on KOHLER® generation systems. A Euroblock connector is a pluggable terminal block that uses screw terminals to clamp connecting wires. It provides a quick, convenient way to connect and disconnect electronic devices.

An important characteristic of RS-485 is the need for a terminating resistor. Without a terminating resistor, messages can interfere with each other. A terminating resistor ensures that the communicated message stops at the last device rather than reflecting or bouncing back and interfering with the next message sent. The generation system specification must detail the special steps required to ensure proper operation when employing an RS-485 serial network.

Communications Hardware and Protocols Used in Electrical Generation Systems

HARDWARE	PROTOCOL	CONNECTOR	CABLE	COMMON APPLICATIONS
RS-485	Modbus RTU	Euroblock	Twisted-Pair (Belden)	Generation system controller to external systems
	Rbus			
CAN	J1939	9-pin D-subminiature	Cable with connector on end	Engine to generator controller, generator to external devices (gauges, I/O, etc.)
	ADEC/MDEC			
	SmartCraft			
	NMEA 2000			
ETHERNET	IP	RJ-45 receptacle	Cable with RJ-45 plug and Cat 5 cable	Building management systems
	Modbus TCP			
	SNMP			
	BACnet			
	LonWorks			
USB	Device Mode	Type B receptacle	Cable with Type B plug	Generator to PC for configuration or data download
	Host Mode	Type A receptacle	Cable with Type A plug	Generator to flash drive to download or upload data

RS-485 CONSIDERATIONS

- RS-485 can be a lower-cost hardware choice compared to other options if the distance is not significant. Because RS-485 requires a twisted-pair cable, it can become costly to run the cable great distances, especially if it needs to be encased in conduit.
- RS-485 can function in distances up to 1200 meters/4000 feet.
- RS-485 works well in electrically noisy environments.
- RS-485 offers relatively lower communication speeds compared to other choices. This is not an issue in most situations, but it could become noticeable if large amounts of data are being transferred.

MODBUS RTU (PROTOCOL)

Modbus RTU (remote terminal unit) is a serial communication protocol developed in the late 1970s. It communicates over the RS-485 hardware layer and is the most common implementation of Modbus. It can be used to communicate with building-management systems, such as SCADA, and other systems that support the protocol.

The Modbus RTU protocol specifies that an individual device on the network must be the primary (master) device while all other devices are secondary (slave). The primary is the only device that can initiate communication activity. All secondary devices react according to the initiation of the primary.

RBUS (PROTOCOL)

Rbus is a KOHLER proprietary protocol developed primarily for use with residential and light commercial products. It communicates over the RS-485 hardware layer and creates a holistic solution among KOHLER generators, transfer switches, programmable interface modules, load control modules and similar devices. Because it is proprietary, it does not allow communication with nonproprietary systems.

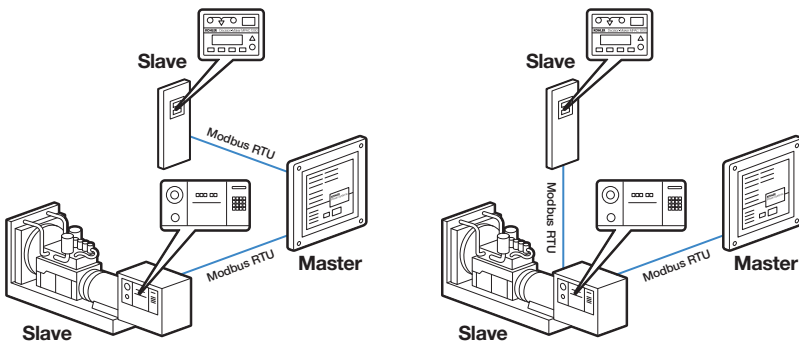

Figure 3: RS-485 Configuration Diagram

CAN

CAN NETWORKS (HARDWARE)

CAN (controller area network), also called CANbus, is a communication network that found its way into the power generation market through its use in engines. CAN is the standard network system for the automotive industry and is used by almost all ECMs (engine control module).

CAN is similar to RS-485 in that it defines the physical manner (voltage, current, number of connectors) in which the devices are connected. CAN does not define the mechanical characteristics of the connection points on each end. A 9-pin, D-subminiature-style connector is often utilized, but other connectors may be employed. Kohler often uses RJ45 connectors for CAN communication.

Another similarity between CAN and RS-485 that should not be overlooked is the need for a terminating resistor to ensure the communicated message stops at the last device rather than reflecting or bouncing back and interfering with the next message sent.

On generation systems, CAN is used to communicate not only with the engine but also with remote input/output boards and external gauges. Kohler typically uses a dedicated CAN network for the ECM and a separate CAN network for all other communication to keep the “chatter” down on the network with the ECM.

CAN CONSIDERATIONS

- CAN is a relatively lower-cost hardware choice due to the common components and short cable distances.
- CAN functions at a relatively shorter distance (40 meters/120 feet) than other options.

- CAN provides excellent immunity to electrically noisy environments.
- CAN’s multinode architecture (as opposed to master-slave) allows devices to communicate without a single point of failure.
- CAN allows for good communication speeds.



Figure 4: 9-Pin D-Subminiature Connector

J1939 (PROTOCOL)

The most common protocol used with CAN is J1939, a standard protocol specified by the Society of Automotive Engineers (SAE). This protocol is found on the network running in many cars throughout the world. It is also used by the majority of generator engine manufacturers.

ADEC/MDEC (PROTOCOL)

ADEC/MDEC (advanced diesel engine control)/ (MTU diesel electronic control) are proprietary CAN protocols owned by manufacturer MTU and used for communications with its ECMs.

SMARTCRAFT (PROTOCOL)

SmartCraft is a CAN protocol developed by Mercury Marine for use in boat systems. Boats employ a wide variety of devices including engine gauges, fire detections systems and radar gear. Because of this, the SmartCraft protocol has been designed to gracefully accommodate identification, addition and removal of devices on the bus.

NMEA 2000 (PROTOCOL)

This protocol was developed by the National Marine Electronics Association for use in marine products. It is used in the marine industry as an alternative to the SmartCraft protocol and J1939.

ETHERNET

ETHERNET NETWORKS (HARDWARE)

Almost everyone is familiar with Ethernet; it is one of the most common ways to access the Internet. The physical manner can vary; for example, as a wired Ethernet connector into a router or a wireless connection via Wi-Fi. Most generation systems that employ Ethernet in their communication solutions use a connector commonly referred to as RJ-45 (remote jack) on the end of a Cat 5 (Category 5) cable.

While the Ethernet network is highly scalable to handle many devices, it does require each device to have a unique ID. Each device is assigned a unique MAC (media access control) address by the manufacturer.

In addition, while Ethernet makes global accessibility to information possible, it also creates security concerns. As such, many businesses deploy additional security measures, such as firewalls, that prevent external devices from accessing internal systems. These additional security measures, along with the fact that every device must have a unique ID, create technical challenges when deploying an Ethernet solution. In most cases, the company's IT (information technology) group is involved to help configure and set up the system.

ETHERNET CONSIDERATIONS

- Ethernet can be costlier than other networking methods due to the additional equipment, such as routers, that it requires.
- Ethernet hardware applications often require involvement of IT experts to get the devices configured and communicating on the internet, intranet or LAN (Local Area Network).
- Ethernet supports very large networks and long distances.
- It integrates well with common networking infrastructure, eliminating the need to be local.
- Ethernet allows for very high communication speeds.
- Ethernet's multinode architecture (as opposed to master-slave) allows devices to communicate without a single point of failure.

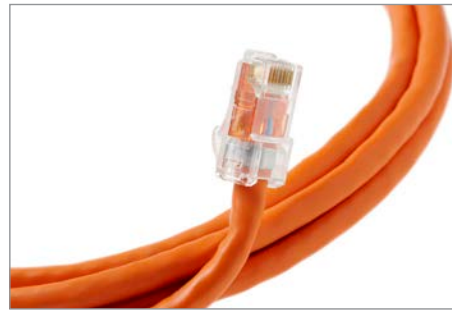

Figure 5: Cat 5 Cable & RJ-45 Connector

INTERNET PROTOCOL (PROTOCOL)

The most common Ethernet protocol is the Internet Protocol (IP). It assigns each device a second address called an IP address. Unlike MAC addresses, which are independent of physical device network location, IP addresses follow a numbering hierarchy that corresponds to device locations within the network structure. Therefore, while a device's MAC address remains fixed, its IP address will change if the device is plugged into a different segment of a network. Network managers allocate a block of IP addresses to each LAN in a network and an individual IP address to each device within a LAN.

A device's address may be programmed manually (in which case the address is called a static IP address) or automatically using a protocol called Dynamic Host Configuration Protocol (DHCP). This is a very important detail when writing a generation system specification. If dynamic IP addresses are used for devices, it may be difficult for digital communication systems to discover the device. Typically, the device will be associated with an IP address. If the Internet service provider changes the IP address through DHCP, inbound connections with the device can be lost.

MODBUS TCP (PROTOCOL)

Modbus TCP (transmission control protocol) communication over Ethernet is a protocol that generally uses Modbus-to-Ethernet converters to create a Modbus-type network to enable remote monitoring or overcome limitations inherent with Modbus RTU, such as distance or the number of master devices on a bus. There can be numerous masters requesting information from the secondary device.

SNMP (PROTOCOL)

SNMP (simple network management protocol) is an Ethernet protocol typically used by building-management systems to monitor for certain messages from devices. In the case of generation systems, SNMP is monitoring for any events that the system may send, such as a fault from the generator. Once the event is sent out via the protocol, it is “trapped” by, and used to generate an alert through, the management system.

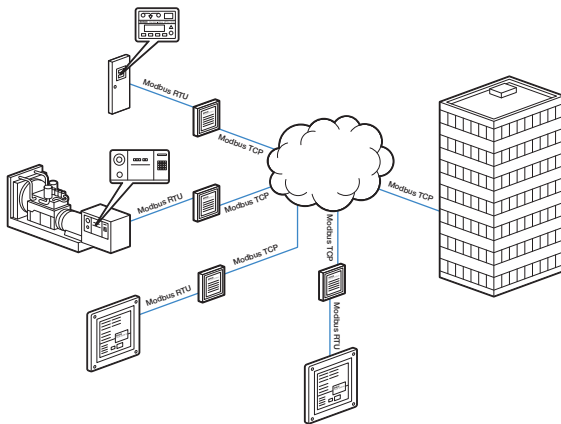

Figure 6: RS-485 Ethernet SNMP Configuration Diagram

BACNET (PROTOCOL)

BACnet (building automation and control networks) is a communication protocol typically used by building-management systems to monitor for certain messages from devices. It is similar to SNMP in that it can be used over a variety of hardware layers, including Ethernet.

LONWORKS (PROTOCOL)

LonWorks (local operation network) is a communication protocol typically used by building-management systems to monitor for certain messages from devices. It is a rival of BACnet and is focused specifically on the needs of control applications. It has been emerging over the last few years but is still used relatively infrequently.

USB

USB COMMUNICATION (HARDWARE)

Given the proliferation of USB (Universal Serial Bus) applications for personal computers, it's natural to see it used within electrical generation systems—mostly to provide access between a computer and the generation system. This access could also

include mass storage devices (e.g., flash drives) for transferring files, such as log files, event files and configuration files, to and from the system.

USB CONSIDERATIONS

- USB is a standard in common use.
- USB provides very fast communication speeds.
- USB operates at relatively shorter distances than other options.
- USB is limited to communication between two devices only, not a network of multiple devices.

USB DEVICE MODE

Generator controllers will communicate via USB device mode with PCs via a program like KOHLER® SiteTech, which is setup software available only to Kohler-certified technicians. The USB connector on the controller allows technicians to interface with SiteTech; Type B connectors are used for USB device mode communications.

KOHLER generator controllers supporting USB device mode include:

- DEC 3000 – Industrial generator controller
- RDC/DC, RDC2/DC2 – Residential generator controllers
- ADC2/ADC2D – Marine generator controllers

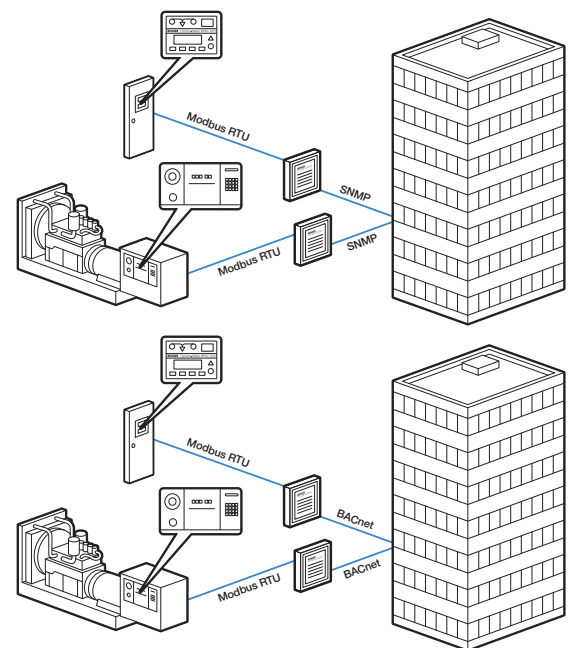

Figure 7: RS-485 Ethernet BACnet Configuration Diagram

USB HOST MODE

Generator controllers that communicate via USB host mode can be reprogrammed using a flash drive (also called a thumb drive or USB memory stick) or can log data to a flash drive. Type A connectors are used for USB host mode.

KOHLER® generator controllers supporting USB host mode include:

- ADC2/ADC2D – Marine generator controllers

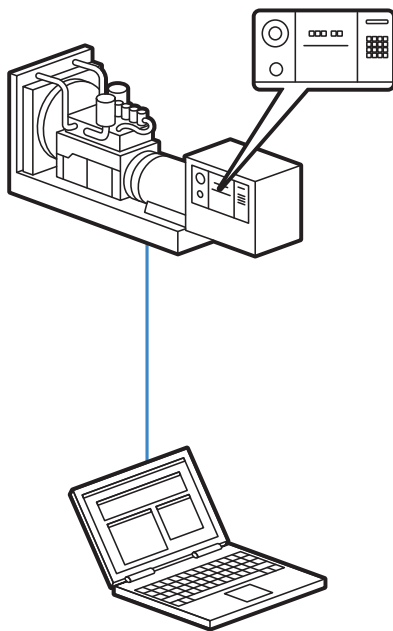

Figure 8: USB Configuration Diagram

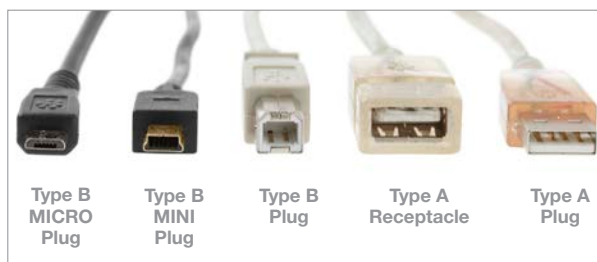

Figure 9: Various USB Connectors

CONCLUSION

There is a large variety of hardware and protocols available today for generator and building systems. The key to choosing the best equipment and systems for your application involves preparation with key stakeholders. Individuals responsible for specifying electrical generation systems must involve all stakeholders to catalog existing devices and systems that need to communicate with the new electrical generation system. These devices may include building management, energy management, security production or other systems. The stakeholders may include information technology experts, building managers, production engineers or other professionals responsible for operations. Using this paper as a guide, this team will develop a thorough description of the current systems' hardware and protocol used by all equipment that will be connected to the generator system. Then, stakeholders should determine how these systems need to communicate, what data must be collected and where all devices are located. With this knowledge, a comprehensive specification can be developed detailing the desired electrical generation system including digital communication hardware and protocol. Do these systems rely on RS-485, CAN and/or Ethernet networks? Which protocols are employed on which systems? What is the distance between devices? Answers to these questions and comprehensive, upfront planning will result in better generator system solutions—and, ultimately, happier customers. KOHLER distributors have the expertise to ensure that your electrical generation system specification and purchase results in the desired functionality.

ABOUT THE AUTHOR



Nicole Dierksheide is a Product Manager with Kohler Power Systems. She holds a Bachelor of Science in electrical engineering from the University of Arizona. Nicole has been with Kohler since 2010 and specializes in statutory controls, digital communication and automatic transfer switches for Kohler Power Systems.

A global force in power solutions since 1920, Kohler is committed to reliable, intelligent products; purposeful engineering and responsive after-sale support. Kohler's acquisition of SDMO in 2005 created one of the world's largest manufacturers of industrial generators. The companies have a combined 150 years experience in industrial power and now benefit from global R&D, manufacturing, sales, service and distribution integration.