

# Using Switchboards With ONBOARD GENERATOR PARALLELING CONTROLS

AUTHOR  
**NICOLE DIERKSHEIDE**  
Director of Marketing

KOHLER CO.  
Power Systems Division

## INTRODUCTION

Paralleling two or more generators offers several practical benefits over a single-generator system. The redundancy inherent in multiple generators delivers greater reliability and flexibility than single-generator installations. In critical or life-safety applications, having multiple generators connected to the bus at all times increases the likelihood of continuous generator power in the unlikely event of a generator failure.

In a multiple generator configuration, individual generators can be turned on or off to track varying load demand, ensuring that each generator is efficiently loaded. Additionally, multiple small generators may cost less than a single large unit. If the largest available generator is too small to meet the power requirements, two or more generators can be paralleled to provide the necessary power. And if one large generator will not fit into the space available, multiple smaller generators can be flexibly utilized instead. Smaller units also weigh less, so rooftop installation becomes a possibility. Convenience in maintenance is also improved, as one generator set can be maintained while others are available to power life-safety loads.

Finally, a paralleled system can be designed to accept additional generators as a facility's load requirements expand.

## ONBOARD PARALLELING MOVES INTO THE MAINSTREAM

While generators have been paralleled for more than 30 years, advancements have occurred with control capability. These advancements have allowed complex paralleling functions; once only available in external, custom-programmed programmable logic controls (PLC) are now offered standard in certain generator controllers. Paralleling generators using their internal control systems is known as onboard paralleling. Over time, this approach has become broadly accepted and risks have been largely minimized or negated.

## ONBOARD PARALLELING SYSTEM EXAMPLE

A typical KOHLER configuration comprises an APM603 controller on each generator, power distribution switchboard, and automatic transfer switches (ATSs). The APM603 enables load sharing, synchronization for up to eight generator sets, generator and load management, and load add/load shed. Optionally, a master control panel can be added for a single point of system control.

The power distribution switchboard provides the connection for the generator sets to create a common bus. It can also accommodate breakers (mechanical or electrically operated), for each generator, and load breakers needed to meet particular customer demands. The ATSs intelligently select the power source, and transfer loads.

## INSTALLATION AND SERVICE CONSIDERATIONS

In North America, generator, ATS, and power distribution switchboard installations must comply with the National Electric Code (NEC). However, it is not a case of a single piece of equipment meeting the code. Instead, approval can only be given to a complete system implementation, with all its components, interconnections, and installation procedures—and this approval is given by a local Authority Having Jurisdiction (AHJ). Each AHJ's decision is based on their own interpretation of the NEC documentation.

Servicing equipment must be considered when designing to allow for proper maintenance and troubleshooting of the system after it is installed. The ability to isolate specific pieces of equipment allows for service without the inconvenience of removing power from large portions of the system. Careful planning of where to place breakers and other disconnecting means can facilitate regular maintenance schedules.

## DESIGN CONFIGURATION OPTIONS, PROS AND CONS

The following configuration examples highlight the differences between using direct generator to ATS connections, and implementations with a generator bus. The underlying theme is about a tradeoff between initial costs and later ease of serviceability.

### CONFIGURATION 1 – DIRECT GENERATOR AND ATS CONNECTION

*Figure 1* represents a connection directly from the generator output to the ATS generator input. With few parts and simple wiring, it offers a low-cost solution, as well as a small footprint. However, there can be a number of practical disadvantages. This configuration will potentially exceed limits for lug amperage ratings and wiring configurations applicable to the ATS's UL1008 listing. While some ATSs have lug connections that will accept multiple cables, these cables would have to be smaller to avoid exceeding the overall cable rating. Similarly, the lug's amperage rating cannot be exceeded.

*Figure 1*

**Direct generator and ATS connection**

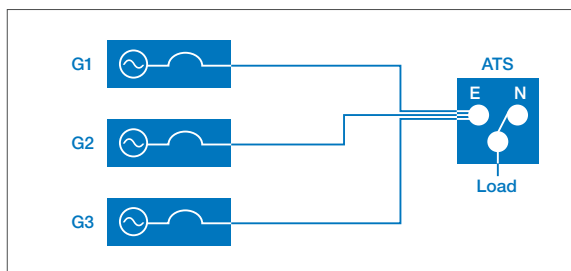

A power distribution block setup could be used; if this is built into the ATS, it must be included within the ATS UL1008 listing. If installed externally to the ATS, it must meet NEC installation guidelines.

This configuration is also limited to a single ATS for multiple generators, so the ATS must be sized for the maximum output of all the generators combined.

Servicing can be problematic as all the generators will need to be shut down to do maintenance since each generator cannot be isolated from the rest. A method for holding the ATS on Normal and preventing it from transferring to Emergency is essential.

### CONFIGURATION 2 – SWITCHBOARD WITH A BUS BREAKER

*Figure 2* shows a switchboard with a bus breaker. The inclusion of the bus breaker facilitates servicing.

This configuration also benefits from a common bus for the generators, with multiple cables replaced by a lower-cost, less space-consuming, easier-to-install single cable run into the ATS lug—provided that the ATS can handle the amperage and cabling, as discussed in *Figure 1* above. However, this challenge can be overcome by connecting multiple ATSs to the common generator bus, to limit the amperage and wiring to each ATS — see *Figure 2.1*.

Multiple ATSs with their own breaker means loads can be separated based on criticality, especially emergency versus nonemergency loads. With loads separated via ATS and breakers, an area with a fault can be isolated without impacting other loads. This allows the system to continue operation, supplying power to the most critical loads.

For example, if a short circuit occurs, the breaker closest to the short circuit source should trip. If the loads are not isolated with a breaker per ATS, the single breaker will trip, disconnecting all loads. Without a breaker, it is not possible to isolate the loads and the entire system will shut down.

Additionally, serviceability is limited in that a single generator cannot be isolated to prevent power reaching the load side of the other generators' breakers.

Figure 2

**Switchboard with a single bus breaker**

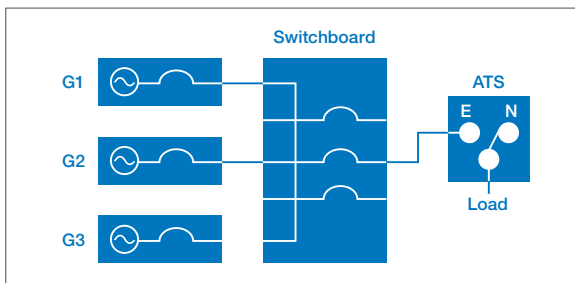
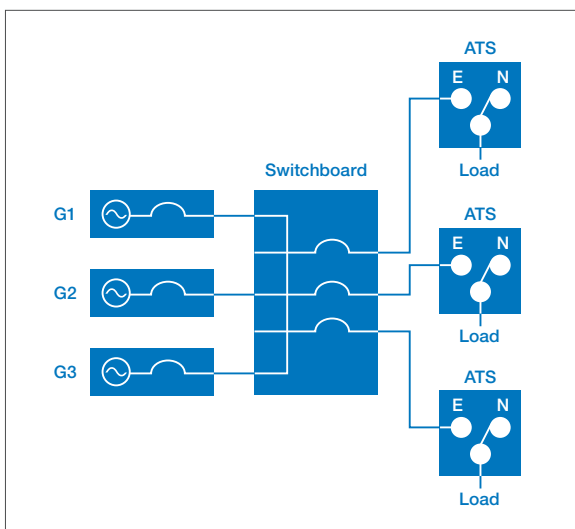

Figure 2.1

**Switchboard with a bus breaker per ATS**



**CONFIGURATION 3 – SWITCHBOARD WITH A BREAKER PAIR PER GENERATOR**

This configuration provides two breakers per generator, with one breaker being on the generator and the other in the switchboard. The electrically operated breaker (EOB) can be on either the generator or the switchboard—whichever works best for the installation.

The configuration offers good serviceability advantages allowing for an N + 1 design system to be serviced while being able to provide full capacity for the loads. It is possible to isolate each generator and prevent power reaching the load side of its breaker. Using two breakers for maximum isolation is the safest approach. There is no need to shut down the entire system to service one generator, the manual breaker on the switchboard would have to be opened to guarantee no power on the generator breaker load side. Without a switchboard breaker, the ATS would have to be switched to manual and left on normal.

Also, as in the *Figure 2* example above, this configuration provides a common bus for the generators. This would connect via a single cable run into the ATS, with all the advantages of installation ease, reduced space, and cost. Multiple ATSs can be added, but each would also require a breaker on the ATS side of the switchboard – see *Figure 3.1*.

Figure 3

**Switchboard with a breaker per generator**

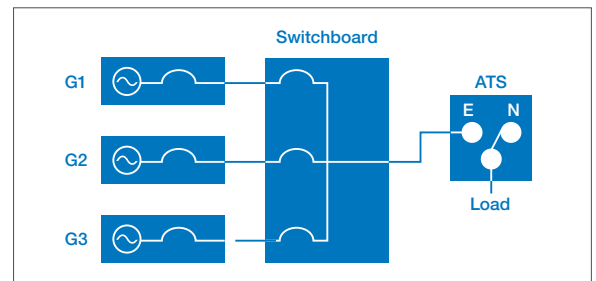

If the switchboard is within line of sight of the generators, a bus bar could be located on the generator with a single EOB per generator in the switchboard. Overall, this is the most flexible design, and allows for expansion with good future planning.

Disadvantages of this scheme compared to [Figure 1](#) are a higher cost and more space requirements.

*Figure 3.1*

**Switchboard with a breaker pair per generator and breaker per ATS**

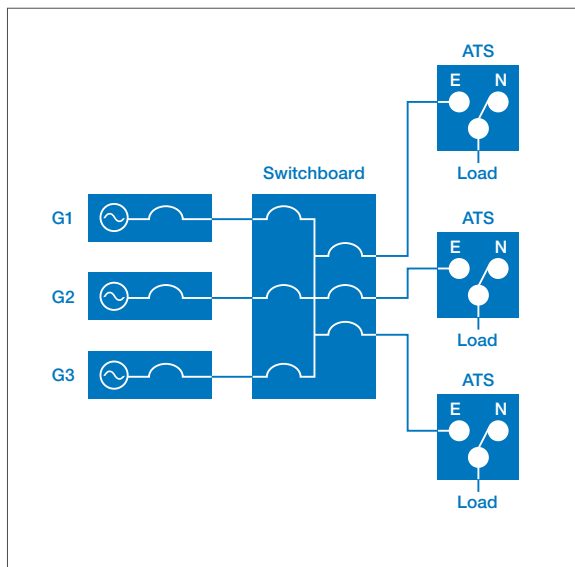

## CONCLUSION

Designing a paralleled generator installation has many factors to consider. Safety and serviceability must always be the highest priority, but cost is clearly important as well. Flexibility comes at a cost.

In these circumstances, it makes good sense to speak to a supplier who can combine breadth of equipment with depth of experience and expertise to deliver a system that performs optimally in your facility under all conditions. Please be sure to reach out to your local Kohler distributor for assistance.

## ABOUT THE AUTHOR



**Nicole Dierksheide** is a Director of Marketing with Kohler Power Systems. She works globally to drive KOHLER® offerings in power generation control and distribution. She holds a bachelor of science in electrical engineering from the University of Arizona. Nicole has been with Kohler since 2010 and specializes in controls, automatic transfer switches, paralleling switchgear, and digital communication. Prior to Kohler, she worked in marketing for a market-leading test and measurement equipment company and in engineering for a transportation company.

A global force in power solutions since 1920, Kohler Co. is committed to reliable, intelligent products; purposeful engineering; and responsive after-sales support. Kohler Co. is among the world's largest manufacturers of industrial generators. The company has 100 years' experience in industrial power and benefits from global R&D, manufacturing, sales, service, and distribution integration.