

KOHLER®

KD Series

800 – 4600 kVA | 800 – 4000 kW

| Power Systems

Power is what we do *Since* 1920

Welcome to an entirely new generator experience. The next leap forward in industrial power. With more than a century of engineering know-how behind them, our new class of KD Series generators are built with an eye on the future—designed to last for decades. Ranging from 800 kVA/800 kW to 4600 kVA/4000 kW, this new range of Industrial Generators is perfectly suited for all industrial applications, providing better fuel economy and a smaller footprint than ever before.

So go ahead and explore our large diesel generators on the pages that follow. When you're ready to customize a system that meets your specific needs, give us a call. With specialized knowledge and an agile manufacturing process, we'll make it happen.

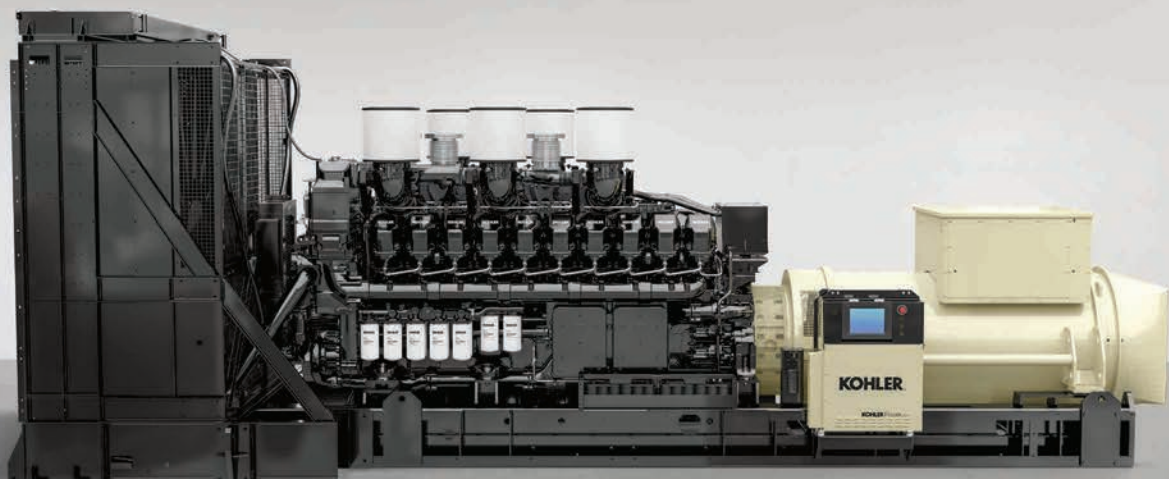
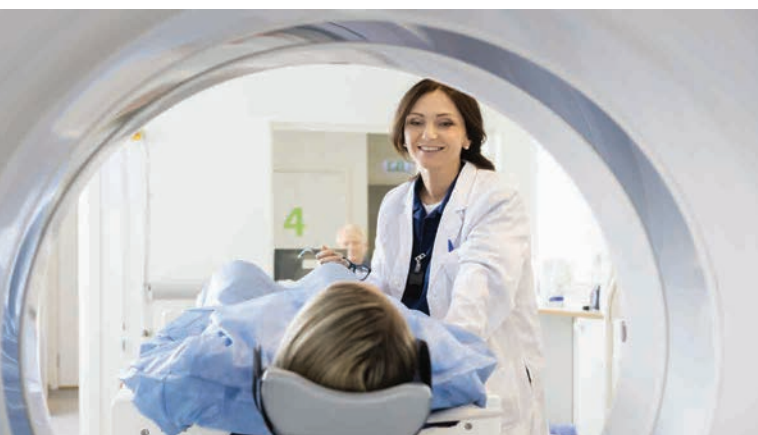

TABLE OF CONTENTS

KOHLER® G-Drive Engines	4
KD Series Generators	6
Specifications	8
Standard Features & Options	10
Enclosures	12
Containers	13
Generator Set Controls	14
M80 & APM403	15
APM802	16
KOHLER Genuine Partst	17
Service & Support.....	18

TARGET APPLICATIONS

Data Centers
Healthcare
Water Treatment
Hospitality
Telecommunications
Mining
Manufacturing
Utilities



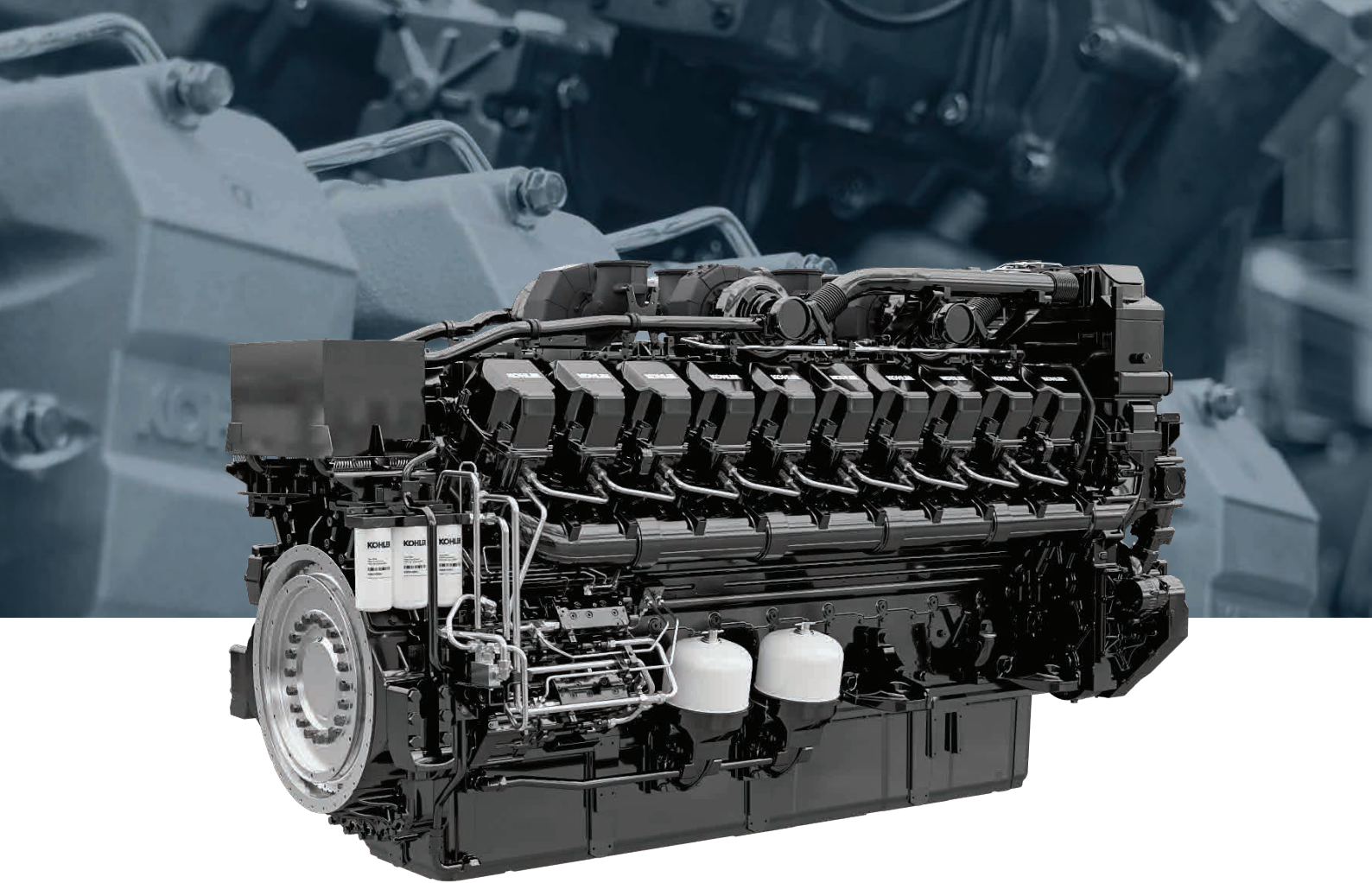

KOHLER® G-DRIVE ENGINES

Massive power in a compact package.

KOHLER G-Drive diesel engines are manufactured with the highest-quality materials and systems. Engineered over a six-year period for use in generator set applications, these engines are built for the toughest environmental conditions. Our G-Drive engines have proven their power and reliability during nearly 50,000 hours of arduous tests under rigorous operating conditions — both in the laboratory and on-site. All of which makes them ideal for a variety of crucial applications such as data centers, healthcare, mining and power plants.

KOHLER G-Drive diesel engines are exclusively manufactured in France and Switzerland, in factories offering the highest level of quality. The range comprises two different engine blocks, the K135 and K175 range, and covers a wide power range: from 709 to 4290 kWm.

CONCENTRATED POWER

KOHLER® G-Drive diesel engines produce industry leading kW displacement in a package that enables a smaller generator set footprint while delivering the best fuel consumption at more nodes than any competitor between 800 and 2500 kW. The engine architecture, injection system and engine management of G-Drive engines have been designed to achieve optimal generator set performance.

OPTIMIZED SOUND LEVEL AND VIBRATIONS

Our G-Drive engine runs smoothly, quietly and with low vibration thanks to its low-noise combustion and optimized combustion pressure. The rigid design of the engine block, crankcase, oil sump, valve cover and subframe also helps reduce vibration. Less friction and vibrations means better reliability, greater strength, a longer service life and minimized fuel consumption.

OPTIMAL CONTROL OF THE INJECTION SYSTEM

Efficient ignition, combustion and exhaust are achieved through a high fuel pressure that produces finely vaporized fuel. Our engine's high fuel pressure common rail injection system reaches an injection pressure of 2200 bar for optimal efficiency and performance.

ROBUST AND RELIABLE

KOHLER G-Drive engines have been purposefully designed for long-life performance inside your generator sets for even the most demanding projects.

SLEEK AND MODULAR DESIGN

Our sleek, modular design means more efficient servicing of the engine, reduced spare parts inventory and more streamlined technician training. It also ensures better accessibility to components for optimized maintenance.



KOHLER GLOBAL SERVICE

Behind every KOHLER Diesel G-Drive engine, there's a world of support. Numerous distributors, sales and service locations, and parts distribution centers make up our network, which extends across the globe. Plus, it's all backed by instant online access to everything from parts information to product warranties.

DAY-TO-DAY EXPERT ASSISTANCE

Kohler provides comprehensive support to engine technicians worldwide by offering:

- Commissioning
- Scheduled and unscheduled maintenance
- Repairs
- Technical documentation
- Product training

KD SERIES™ GENERATORS

Built for the most critical jobs on earth.

REVOLUTIONARY AND RELIABLE

We engineer, test and fit every single component of our G-Drive engines. Our computer-aided quality-management system oversees every step of development, from the first stage of production through the engine's entire lifecycle, to ensure the highest level of quality.

TESTED AND APPROVED

Created specifically for generator set applications, our G-Drive engines combine greater power with superior efficiency. Reaching up to 43.5 kW/liter, KOHLER® G-Drive engines pair a compact engine with unrivaled kW displacement—delivering the highest power density on the market*. All KOHLER generators meet tough industry testing and quality standards (UL2200, CSA, NFPA).

SMOOTH-RUNNING

The KOHLER G-Drive engine runs smoothly, quietly and with low vibration—even under extreme operating conditions—extending service life and delivering cost-effective performance.

CONTROL AND MAINTENANCE

KD Series generators feature integrated controls for seamless communication and offer remote monitoring through a VPN connection. Easy-access bearing lube points, coolant level optical gauges on both circuits and oil replenishment systems help ensure the generator runs optimally and is easy to maintain.

ULTIMATE PERFORMANCE

The KOHLER G-Drive diesel engine's architecture, injection system and engine management have been designed to achieve optimal generator set performance.

FUEL-EFFICIENT

The common rail fuel system generates up to 2200-bar injection pressures for maximum efficiency, optimizing the combustion pressure curve through multiple injections. This produces industry-leading kW displacement in a package that enables a smaller generator set footprint while delivering the best fuel consumption at more nodes than any competitor between 800 kW and 2500 kW.

COMMON SERVICE PART NUMBERS

A modular system allows us to scale the number of components depending on the power required. Using standard components means fewer parts must be stocked in the field, and operators require less training. This reduces costs and improves response time.

*Higher power density at more nodes than any competitor between 800 – 2500 kW.

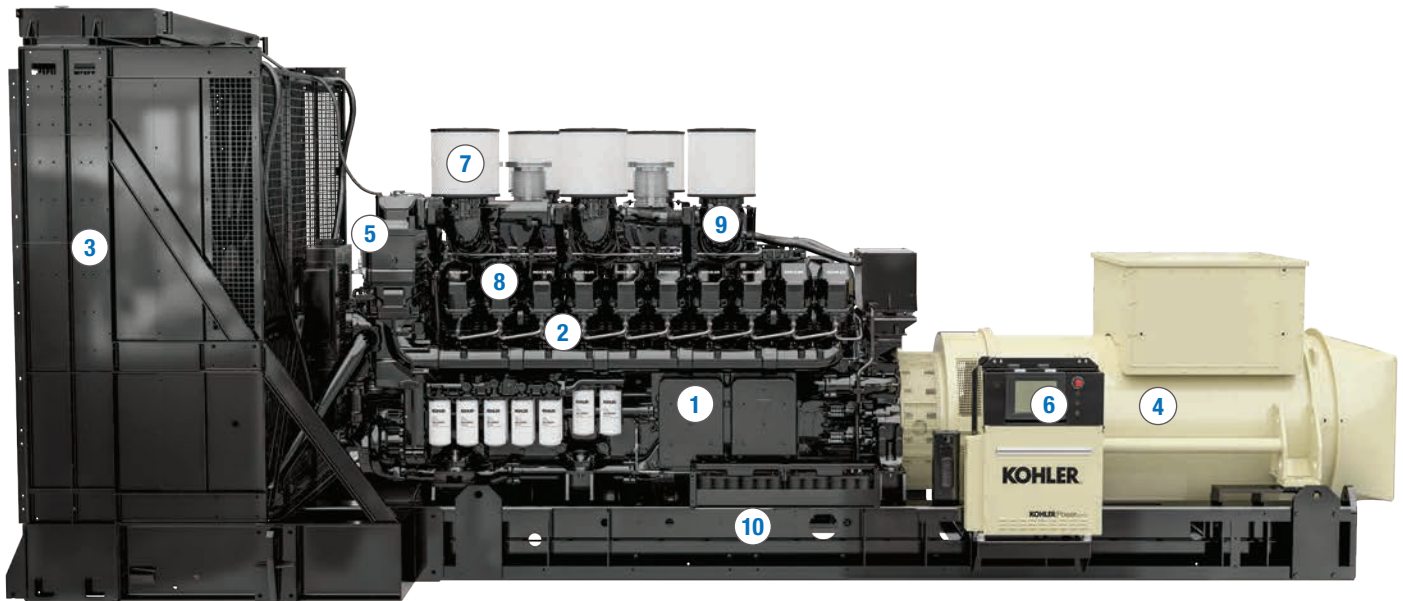

1 EMISSION OR FUEL OPTIMIZED ENGINE
Clean-running engines, featuring closed crankcase ventilation design. Available in emission or fuel optimized version to meet your requirement on emissions standards or low fuel consumption

2 FUEL SYSTEMS
Common rail injection systems, designed specifically for the KOHLER large diesel. Enables injection at a pressure up to 2200 bar for maximum efficiency

3 HIGH-AMBIENT COOLING SYSTEMS
Designed to meet extreme operating conditions, segmented radiator core sections allow for single replacement instead of entire core.

4 EFFICIENT ALTERNATORS
Provide advanced short circuit capability and meet NEMA MG 1, IEEE and ANSI standards; multiple alternator options available

5 ENGINE CONTROL UNIT (ECU)
ECU and KOHLER controllers communicate seamlessly with one another for easier maintenance and service

6 KOHLER GENERATOR CONTROLLERS
Generator set controller, designed by Kohler to control all functions and guarantee optimal performance. The large touch screen on the ergonomic human-machine interface makes for easy operation on paralleling, load and generator management

7 LOW COMBUSTION AIR
Requires less air to run, creating fewer emissions and enabling optimal performance inside an enclosure

8 INNOVATIVE CYLINDER HEAD
An innovative cylinder head design enabling better circulation of fuel, more efficient combustion and optimized exhaust gas emission flow

9 TURBOCHARGERS
The turbochargers are designed for maximum power and optimal combustion. They are adapted to each engine to continuously supply the required amount of air, reducing the fuel consumption and improving operation at high altitude

10 OPTIONS AND ACCESSORIES
Multiple circuit breakers, battery heaters, block heaters, battery charger, prelube pump and centrifugal oil filter

SPECIFICATIONS

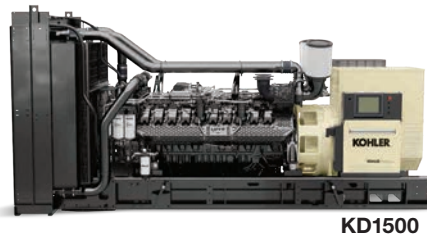
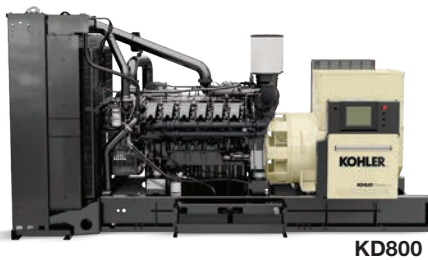

50Hz

US MODELS	STANDBY(kW/kVA)	PRIME (kW/kVA)
KD800-YF	720/900	632/790
KD900-YF	800/1000	720/900
KD1000-YF	880/1100	792/990
KD1250-YF	1152/1440	1040/1300
KD1350-YF	1200/1500	1080/1350
KD1500-YF	1210/1510	1100/1375
KD1600-YF	1320/1650	1184/1480
KD1750-YF	1440/1800	1296/1620
KD2000-YF	1600/2000	1456/1820
KD2250-YF	2000/2500	1816/2270
KD2500-YF	2240/2800	2032/2540
KD2800-YF	2400/3000	2176/2720
KD3000-YF	2640/3300	2400/3000
KD3250-YF	2800/3500	2544/3180

FRANCE MODELS	STANDBY (kW/kVA)	PRIME (kW/kVA)
KD800-E/F	640/800	582/727
KD900-E/F	720/900	654/818
KD1000-E/F	800/1000	727/909
KD1100-E/F	880/1100	800/1000
KD1250-E/F	1000/1250	909/1136
KD1400-E/F	1136/1420	1033/1291
KD1500-E/F	1231/1540	1120/1400
KD1650-E/F	1320/1650	1200/1500
KD1800-E/F	1440/1800	1309/1636
KD2000-E/F	1600/2000	1454/1818
KD2250-E/F	1800/2250	1636/2045
KD2500-E/F	2000/2500	1818/2273
KD2800-E/F	2240/2800	2036/2545
KD3100-E/F	2480/3100	2254/2818
KD3300-E/F	2640/3300	2400/3000
KD3500-E/F	2800/3500	2546/3182
KD3750-E/F	3000/3750	2727/3409
KD4000-E/F	3488/4360	3176/3970
KD4500-E/F	3680/4600	3344/4180

60 Hz

US MODELS	STANDBY(kW/kVA)	PRIME (kW/kVA)
KD800	800/1000	720/900
KD900	900/1125	810/1012
KD1000	1000/1250	900/1125
KD1250	1250/1562	1120/1400
KD1350	1350/1687	1210/1512
KD1500	1500/1875	1350/1688
KD1600	1600/2000	1440/1800
KD1750	1750/2188	1580/1975
KD2000	2000/2500	1810/2262
KD2250	2250/2812	2040/2550
KD2500	2500/3125	2270/2838
KD2800	2800/3500	2540/3175
KD3000	3000/3750	2720/3400
KD3250	3250/4062	2950/3688
KD3500	3500/4375	3180/3975
KD4000	4000/5000	3640/4500

FRANCE MODELS	STANDBY (kW/kVA)	PRIME (kW/kVA)
KD800-UE/F	800/1000	727/909
KD900-UE/F	920/1150	836/1045
KD1000-UE/F	1000/1250	909/1136
KD1250-UE/F	1250/1563	1137/1421
KD1350-UE/F	1339/1674	1218/1522
KD1500-UE/F	1500/1875	1364/1705
KD1600-UE/F	1600/2000	1454/1818
KD1750-UE/F	1728/2160	1571/1964
KD2000-UE/F	2000/2500	1818/2273
KD2250-UE/F	2248/2810	2044/2555
KD2500-UE/F	2500/3125	2273/2841
KD2800-UE/UF	2814/3518	2558/3198
KD3000-UE/UF	3000/3750	2727/3409
KD3250-UE/UF	3250/4062.5	2954/3693

Disclaimer: Information in this publication represents product data available at the time of print. Kohler reserves the right to change this publication and the products represented without notice and without any obligation or liability.

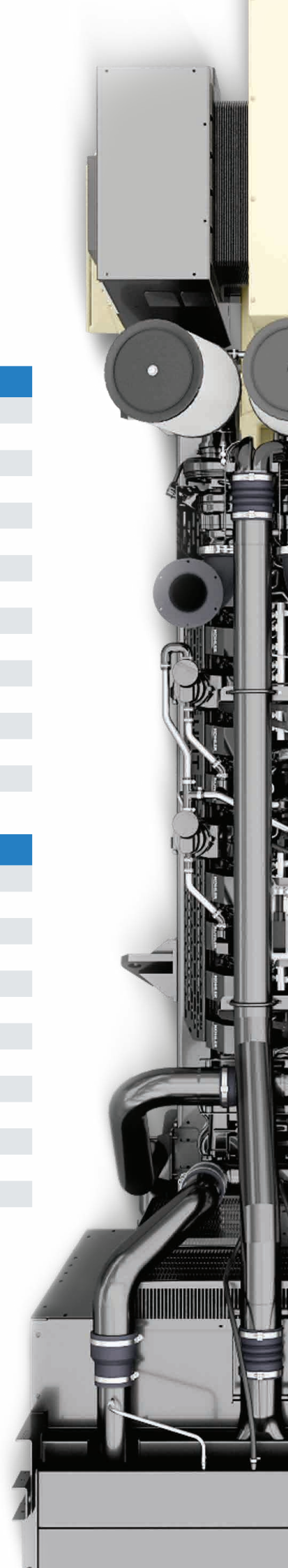

STANDARD FEATURES AND OPTIONS

For each of its generators, Kohler offers a large range of options to facilitate maintenance operations, enhance user safety and provide solutions for specific user requirements or demanding environments.

	KD800	KD900	KD1000	KD1100	KD1250	KD1350	KD1400	KD1500	KD1600	KD1650	KD1750	KD1800
50 Hz (400-230 V)	X	X	X	X	X	-	X	X	-	X	-	X
60 Hz (480-277 V)	X	X	X	-	X	X	-	X	X	-	X	-

	KD2000	KD2250	KD2500	KD2800	KD3000	KD3100	KD3250	KD3300	KD3500	KD4000	KD4500
50 Hz (400-230 V)	X	X	X	X	-	X	-	X	X	X*	X*
60 Hz (480-277 V)	X	X	X	X	X	-	X	-	X*	X*	-

*Only available in MV and HV

		KD800 - KD1800	KD2000 - KD4500
Engine	4 stroke water-cooled diesel engine	•	•
	Electronic control device	•	•
	Standard air filter	•	•
	Air filter with interchangeable cartridge	EN02 ⁽¹⁾	EN02
	Pre-lubrication pump	X	EN25
	Dual starting	SO007	SO007
Alternator	IP 23 single bearing alternator, T ⁺ class =H, insulation class H/H	•	•
	Anti-condensation resistor	AL01	AL01
	Type D impregnation	•	•
	Type R impregnation	AL06	AL06
	CT coupling	o ⁽²⁾	o ⁽²⁾
	Oversized alternator	A0001B	A0001B*
Generator set	CE compliance of the control unit	•	•
	Mechanically welded base frame with antivibration dampers	•	•
	High-efficiency vibration damping	ISO1	•
Lubrication	Automatic oil make up with tank	EN18	EN18
	Oil centrifuging system	X	EN19
	Oil drainage pump	•	•
Cooling	Protective grille for fan and rotating parts	•	X
	Vertical air cooler supplied separately	X	CS001C
	Kit for assembling the air cooler on the unit	X	MA001
	Protective grille for radiator core	EN14	X
Exhaust	Exhaust compensators with clamps	•	•
	Protective grille for hot parts	CEL02	X
	9 dB(A) silencer supplied separately	EN07	EN07
	29 dB(A) silencer supplied separately	EN08	EN08
Starting	40 dB(A) silencer supplied separately	EN09	EN09
	24 V charging alternator and starter	•	•
	Starter batteries	SO001	SO001
Fuel	Battery isolating switch	EN16	EN16
	Generating set without fuel tank	• ⁽³⁾	•
	Separate fuel tank on 500 L bund	FD06	FD06
	Separate fuel tank on 1000 L bund	FD07	FD07
	500 L base frame fuel tank	FD03 ⁽³⁾	X
	930 L base frame fuel tank, enclosed version	•	X
	Retention bund level alarm	FD14	FD14
	1m ³ /h 1-pump auto kit	FD08	FD08
	1 m ³ /h 2-pump auto kit	FD09	FD09
	Diesel separator pre-filter	•	•

• As standard
 X Not available
 O Several options available - please contact us
 EN01: option code
 *Applies to KD2000 - KD2500

⁽¹⁾ Please contact us for ISO20 container versions
⁽²⁾ CT coupling not necessary with APM802
⁽³⁾ Except enclosed gensets

France models

1 DIESEL SEPARATOR PRE-FILTER

This is a filter that enables water contained in the diesel to be removed, thereby improving the engine's protection.

2 FILTER WITH INTERCHANGEABLE CARTRIDGE (EN02)

These dry air filters with removable and interchangeable cartridge for dusty environments can be removed and cleaned with blown air. This option is required when the generator set is used in dusty environments.

3 OVERSIZED ALTERNATOR (AO001B)

For installations with significant electrical constraints, this option ensures improved performance.

4 IMPREGNATION

D-type: for tropical type environments with relative humidity > 95%, excluding coastal environments.

R-type: for harsh industrial environments with humidity level > 95% and coastal environments.

5 SILENCER IN OPEN VERSION (EN07, EN08, EN09)

For "open" version of the generator sets, 3 noise reduction levels are available to meet the constraints of various installations: 9 dB(A), 29 dB(A) et 40 dB(A).

6 OIL CENTRIFUGE (EN19 ONLY FOR KD2000 - KD3500)

This allows the maintenance interval to be increased from 500 hours to 1500 hours (depending on the oil quality).

7 AUTOMATIC OIL MAKE UP WITH TANK (EN18)

Automatic oil make up system enables a constant oil level to be maintained in the crankcase during operation. It comprises a new oil reserve, an oil level regulator and a hose and valve assembly mounted on the generator set's base frame.

8 AUTOMATIC FUEL FILLING KIT (FD08)

This kit allows the fuel tank to be automatically filled from an external storage tank. It includes:

- an electric pump with automatic control governed by a gauge with level contacts.
- a manual back-up pump.

It can be used for extended periods of time without topping up the diesel. It is particularly well-suited for remote locations.



ENCLOSURES

Keeping the noise in.

KOHLER® enclosures are bolstered by heavy-duty aluminum and acoustic insulation to protect your investment and keep the noise down. In addition, we coat every unit* with Power Armor™ (a textured industrial finish) for heavy-duty durability in harsh conditions. The new design includes a sloped roof to increase the life and safety of the generator.

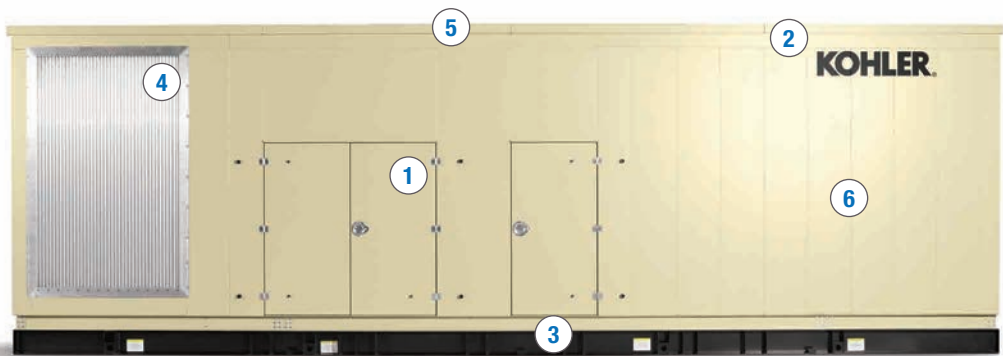

KD1750*

- 1 SERVICE ACCESS**
Multiple personnel doors and removable panels offer easy access to generator control, fuel fill, fuel gauge, oil fill and battery
- 2 INTERNAL EXHAUST SYSTEM**
Features insulated exhaust silencer for improved aesthetics, safety and noise reduction
- 3 OIL AND RADIATOR DRAINS**
Provide an easier, quicker way to service your generator
- 4 AIR INLETS**
Louvered air inlets limit water ingress and shorten overall length of enclosure
- 5 SLOPED ROOF**
Reduces water pooling and increases enclosure shelf life
- 6 AVAILABLE ACCESSORIES**
Electrical packages, heaters, motorized louvers, stairs and more

STANDARD FEATURES

Fitted Enclosures

Sound enclosures feature durable aluminum construction, stainless steel external hardware and an LED emergency lighting system.

Quiet Performance

Our SL1 and SL2 enclosures offer acoustic insulation to meet your quiet applications.

Advanced Corrosion Protection

Power Armor* is a textured automotive-grade finish that surpasses a 2500-hour salt spray exposure test and resists fading and scratching.

Certified Packages

Enclosures are UL2200 tested and approved, IBC-certified, OSHPD-certified and meets up to 181-mph wind rating.

*US models only.

**France models only.



M427**

CONTAINERS

A versatile range of soundproofed containers.

You are faced with numerous installation constraints. Our containers can be adapted to meet all your needs. Thanks to their standard dimensions, they are easy to transport. Our turnkey containers have an integrated fuel tank which means they are ready to run. Their coolant systems, with an integrated silencer and sound traps, provide a highly economical solution.

ISO CONTAINERS



ISO containers are adapted to emergency applications with no harsh environmental constraints.

Available as 20-foot High Cube



CSC* certified



Adapted to standard environments

PRODUCT PLUS POINTS

- Flexible Integration
- Low Sound Level
- No Loss of Power up to 40°C
- Simplified Maintenance
- Accessible Control/Command and Power Components
- Short Production Lead Times

CPU CONTAINERS



CPU type containers are designed to be adapted to the most demanding environments. Robust and modular, they are specially conceived to meet the very stringent constraints of production applications.

Available as 40-foot High Cube

France models



CSC* certified



Double maintenance door



Harsh atmospheres (heat, dust)

GENERATOR SET CONTROLS

Kohler offers a unique range of specific control units: M80, APM403 and APM802. These control units offer a wide range of possibilities, from simplified running to the option of managing the most complex coupling operations, and can be adapted to suit every need. Note that the modularity is made easier by the fact that each optional peripheral device (air cooler, daily service tank, oil make up, etc.) has its own protection. The M80 and APM403 control units are available for France models only.

COMPARISON OF THE 3 CONTROL UNITS

SPECIFICATIONS	M80	APM403	APM802
DISPLAY			
Frequency	X	•	•
Phase to neutral voltages	X	•	•
Phase to phase voltages	X	•	•
Currents	X	•	•
Active/reactive/apparent power	X	•	•
Power factor	X	•	•
Battery voltage	•	•	•
Battery current	X	0	0
Start-up delay	X	•	•
Fuel level	X	•	•
Oil pressure	•	•	•
Coolant temperature	•	•	•
Oil temperature	•	0	0
Total working hours counter	•	•	•
Partial working hours counter	X	•	•
Total active/reactive energy meter	X	•	•
Engine speed	•	•	•
FAULT INFORMATION (fault or alarm)			
Min/max alternator voltage	X	•	•
Min/max alternator frequency	X	•	•
Min/max battery voltage	X	•	•
Overload and/or short circuit	X	•	•
Active/reactive power return	X	•	•
Oil pressure	•	•	•
Coolant temperature	•	•	•
Speed too high	•	•	•
Underspeed	X	•	•
Low fuel level	X	•	•
Emergency stop fault	X	•	•
Non-starting fault	X	•	•
Charging alternator fault	X	•	•
Differential relay activation fault	X	•	•
General alarm	X	•	•
General fault	X	•	•
Sound alarm	X	•	•

• As standard
 X Not available
 0 Optional
 - APM403 only

SPECIFICATIONS	M80	APM403	APM802
OPERATION			
Power ON	X	•	•
Manual genset starting	X	•	•
Automatic genset starting	X	•	•
Genset shut down	X	•	•
Emergency stop	•	•	•
Menu navigation using colour touch-screen	X	X	•
Operating configuration selector	X	•	•
Remote starting control	X	0	0
Speed adjustment	X	•	•
Voltage adjustment	X	•	•
Dual frequency	X	•	0
Delayed start programming	X	•	•
Multilingual text	X	•	•
Websupervisor	X	0	X
CONNECTIVITY			
Ethernet port (website)	X	•	•
RS485 (JBUS protocol)	X	•	•
Engine CAN Bus (J1939)	X	•	•
USB port (config and software downloading)	X	•	•
MOD BUS	X	•	•
4G, GPRS, GSM	X	0	0
TCP/IP	X	0	0
COUPLING			
Under load	X	-	•
Stopped	X	-	•
Droop distribution of active and reactive power	X	-	•
Parallel line distribution of active and reactive power	X	-	•
CAN Bus distribution of active/reactive power	X	-	•
Power plant wattmeter control	X	-	•
Temporary coupling of Out/Return grid	X	-	•
Power plant coupling to grid (temporary, permanent, etc.)	X	-	•
GENERAL			
Downloading of a customized configuration via USB port	X	•	•

M80 CONTROLLER

Dual-Function.

The M80 can be used as a basic terminal block for connecting an electrical cabinet box and as an instrument panel with a highly intuitive LCD screen giving an overview of your generator set's basic parameters. It is equipped with an emergency stop button and a customer terminal block, and has CE conformity.



The screen can display all of the engine's physical values:

- oil gauge
- coolant temperature
- oil temperature
- engine speed
- battery voltage
- charge air temperature
- fuel consumption
- etc.

The engine faults can also be displayed. The M80 records several events to facilitate diagnostics and can control the main engine functions:

- starting
- speed adjustment
- stopping
- droop
- etc.

APM403 CONTROLLER

Intuitive and Versatile.

The APM403 controller is simple to use and comes with built in intuitive configurations to cater to different backup system setups. It is available in 2 different models. The APM403S is specially design to offer the best command and control capabilities for a single generator set operation. The APM403P offers the additional versatility of paralleling multiple generator sets together or even parallel together with mains.

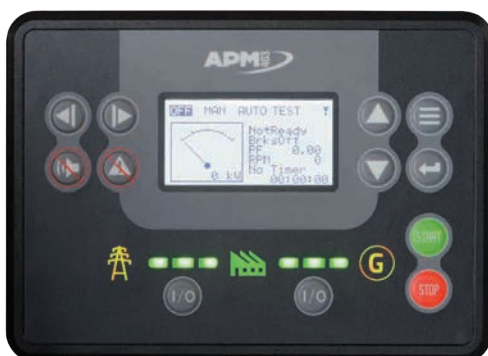

- **CONTROL**
Basic control for speed and voltage
- **MEASUREMENTS AND DISPLAYS**
Mechanical and electrical measurement and display
- **SOLO OR PARALLEL**
Single generator set control or parallel with up to 8 generator sets
- **SAFETY AND PROTECTION**
Built in electrical protection features

- **POWER SUPPLY**
12V or 24V
- **AUTOMATIC MODE**
Auto start and stop, depending on load requirement
- **REMOTE MANAGEMENT AND MONITORING**
Offers real time monitoring and even control of a single or multiple generator sets

APM802 DIGITAL CONTROLLER

Technology so advanced, it's easy.

The APM802 command/control system is specifically designed for operating and monitoring power plants for markets including hospitals, data centres, banks, oil and gas sector, IPP and mining. The Human Machine Interface (HMI), designed in collaboration with a company specializing in interface design, facilitates operations with a large 100% touch screen. The pre-configured system for power plant applications features a brand new customization function which complies with the international standard IEC 61131-3.

OPERATING SCREEN



Illustration may vary from actual product.

ETHERNET COMMUNICATION: INNOVATIVE AND PATENTED

Communication via APM802 guarantees a high level of equipment availability and facilitates the remote control of the HMI for an enhanced user experience. Additionally, various connections can be made via the Ethernet using fibre optics or combined with copper wire. System communications are separated from external communications to allow full control of risk management.

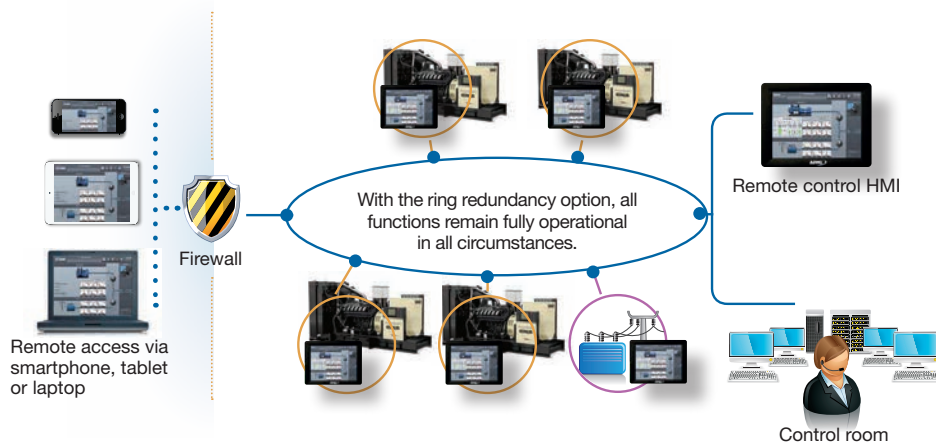

The ring is created by several Ethernet segments and groups together regulation and PLC communications.



SERVICE AND SUPPORT

The help you need.
Any time, anywhere.

You're never too far from Kohler. Across the world, more than 800 locations are ready to provide sales, installation, and aftermarket support services. And each one offers expertise in power specifications, equipment, and integration. There's no question they can't answer. We should know, we

trained them ourselves. Plus, if you ever need assistance in the middle of the night, we'll take care of you. Kohler Power professionals are available to offer troubleshooting, advice, service, and support.



KOHLER

- ① Headquarters and Manufacturing—Kohler, Wisconsin
- ② Headquarters EMEA
- ③ Headquarters Asia Pacific and Manufacturing—Singapore
- ④ Manufacturing Facility—China
- ⑤ Manufacturing Facility—France
- ⑥ Manufacturing Facility—Brazil
- Sales Offices, Dealers and Distributors

KOHLER[®]

Southeast Asia (Regional HQ)
Singapore +65 6264 6422
sales.sg@kohler.com

Learn more at [POWERSYSTEMS-SEA.KOHLERENERGY.COM](https://powersystems-sea.kohlerenergy.com)

PRINTED IN SINGAPORE 09/23 G12-478-SEA © 2023 BY KOHLER CO.